



Cálculo del coeficiente de transmisión térmica (Uf)

Ventana Desplazable M-Tres, con poliamida de 25

Cliente:

Alcemar

Cálculos realizados por

Technoform BAUTEC Ibérica, s.l.

Laia Cardona

Tel: +34 93 238 64 38/ Fax: +34 93 415 40 37

Email: tb-es@technoform.es

Fecha:

18.04.2006

Resultados

Ventana Desplazable RPT M-3/25 mediante BISCO según norma EN ISO 10077-2:2003	Uf = 3,41 W/m ² K
Ventana Desplazable RPT M-3/25 mediante RADCON con “Know-How” TECHNOFORM	Uf = 3,16 W/m ² K

En este informe se determina el coeficiente de transmisión térmica (Uf) mediante dos métodos de cálculo diferentes:

- A) Aplicando la norma EN ISO 10077-2:2003, y usando el software “BISCO” de la empresa Physibel.
- B) Aplicando un método propio, “know-how” de Technoform, donde se usa el software “RADCON”- también propiedad de Physibel - y el valor final equivale aproximadamente al resultado en el test de cálculo de nuestra HOT-BOX (La diferencia es de un 5%) según norma ISO/FDIS 12567:2000.

Contenido

- Dibujo sistema

A) mediante BISCO según norma EN ISO 10077-2:2003

- Input – data BISCO
- Output – data BISCO
- Cálculo del coeficiente de transmisión térmica (U_f)
- Isotermas
- Flujo de calor

B) mediante RADCON con “Know-How” TECHNOFORM

- Input – data RADCON
- Output – data RADCON
- Cálculo del coeficiente de transmisión térmica (U_f)

Dibujo sistema

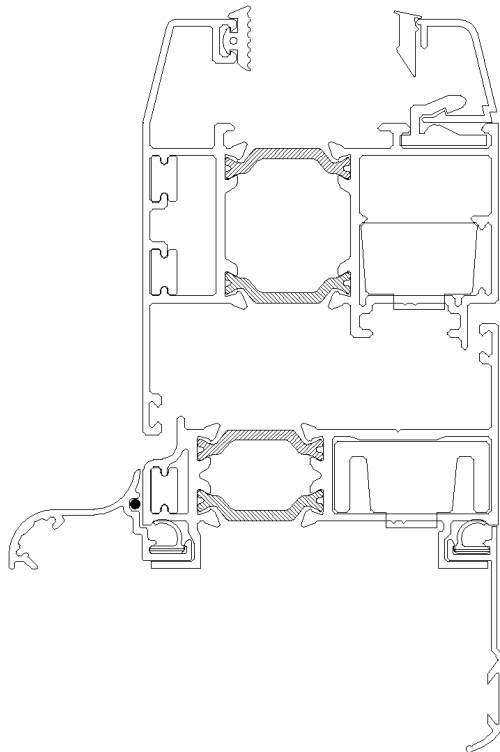



A) mediante BISCO según norma EN ISO 10077-2:2003

Input – data BISCO

Col.	Name	Type	CEN-rule	Coupled	lambda [W/mK]	eps [-]	t [°C]	h [W/m²K]
8	aluminium	MATERIAL			160.000			
28	insulation	MATERIAL			0.035			
44	polyamid reinf.	MATERIAL			0.300			
60	EPDM	MATERIAL			0.250			
119	temp. sensor 1	MATERIAL			160.000			
135	temp. sensor 2	MATERIAL			160.000			
151	temp. sensor 3	MATERIAL			160.000			
170	exterior	BC_SIMPL	HE				0.0	25.00
174	interior (norma	BC_SIMPL	HI_NORML				20.0	7.70
182	interior (reduc	BC_SIMPL	HI_REDUCE				20.0	5.00
214	cavity (CEN)	EQUIMAT	CEN_VF_I	NO	0.170			
215	cavity (CEN)	EQUIMAT	CEN_VF_I	NO	0.044			
216	cavity (CEN)	EQUIMAT	CEN_VF_I	NO	0.083			
217	cavity (CEN)	EQUIMAT	CEN_VF_I	NO	0.106			
218	cavity (CEN)	EQUIMAT	CEN_VF_I	NO	0.239			
219	cavity (CEN)	EQUIMAT	CEN_VF_I	NO	0.064			
220	cavity (CEN)	EQUIMAT	CEN_VF_I	NO	0.102			
221	cavity (CEN)	EQUIMAT	CEN_VF_I	NO	0.102			
222	cavity (CEN)	EQUIMAT	CEN_VF_I	NO	0.184			
240	cavity (CEN)	EQUIMAT	CEN_VF_E	NO	0.094			
241	cavity (CEN)	EQUIMAT	CEN_VF_E	NO	0.099			
242	cavity (CEN)	EQUIMAT	CEN_VF_E	NO	0.081			
243	cavity (CEN)	EQUIMAT	CEN_VF_E	NO	0.081			
250	cavity <4x4 mm2	MATERIAL			0.037			
252	cavity <2x2 mm2	MATERIAL			0.031			
253	cavity <1x1 mm2	MATERIAL			0.028			

Col.	q [W/m²]	ta [°C]	hc [W/m²K]	qc [W/m]	tr [°C]	C1 [-]	C2 [-]	C3 [-]
8								
28								
44								
60								
119								
135								
151								
170	0							
174	0							
182	0							
214						0.025	0.73	0.333333
215						0.025	0.73	0.333333
216						0.025	0.73	0.333333
217						0.025	0.73	0.333333
218						0.025	0.73	0.333333
219						0.025	0.73	0.333333
220						0.025	0.73	0.333333
221						0.025	0.73	0.333333



222	0.025	0.73	0.333333
240	0.025	0.73	0.333333
241	0.025	0.73	0.333333
242	0.025	0.73	0.333333
243	0.025	0.73	0.333333
250			
252			
253			

Calculation parameters

Contour approximation margin (triangulation) = 0 pixels
 Iteration cycles = 5
 Recalculation of CEN values (before each iteration cycle)
 Maximum number of iterations (per iteration cycle) = 10000
 Maximum temperature difference = 0.0001°C
 Max. heat flow divergence for total object = 0.001 %
 Max. heat flow divergence for any node = 1 %

Output – data BISCO

Col.	Name	Type	tmin [°C]	tmax [°C]	ta [°C]	flow in [W/m]	flow out [W/m]
8	aluminium	MATERIAL	2.23	12.44			
28	insulation	MATERIAL	0.79	17.32			
44	polyamid reinf.	MATERIAL	2.48	12.06			
60	EPDM	MATERIAL	1.58	13.26			
119	temp. sensor 1	MATERIAL	12.09	12.09			
135	temp. sensor 2	MATERIAL	12.29	12.29			
151	temp. sensor 3	MATERIAL	15.70	15.70			
170	exterior	BC_SIMPL	0.79	2.62		0.00	11.30
174	interior (norma	BC_SIMPL	12.06	17.32		10.38	0.00
182	interior (reduc	BC_SIMPL	12.42	16.60		0.92	0.00
214	cavity (CEN)	EQUIMAT	2.63	12.05			
215	cavity (CEN)	EQUIMAT	2.60	2.63			
216	cavity (CEN)	EQUIMAT	2.63	11.91			
217	cavity (CEN)	EQUIMAT	11.91	12.10			
218	cavity (CEN)	EQUIMAT	2.43	12.17			
219	cavity (CEN)	EQUIMAT	2.36	2.52			
220	cavity (CEN)	EQUIMAT	2.49	12.05			
221	cavity (CEN)	EQUIMAT	12.03	12.30			
222	cavity (CEN)	EQUIMAT	2.23	13.14			
240	cavity (CEN)	EQUIMAT	1.50	2.63			
241	cavity (CEN)	EQUIMAT	12.04	13.43			
242	cavity (CEN)	EQUIMAT	1.60	2.62			
243	cavity (CEN)	EQUIMAT	12.16	13.07			
250	cavity <4x4 mm2	MATERIAL	12.14	12.34			
252	cavity <2x2 mm2	MATERIAL	2.12	2.31			
253	cavity <1x1 mm2	MATERIAL	1.79	12.61			



Cálculo del coeficiente de transmisión térmica (Uf)

THERMAL TRANSMITTANCE ACCORDING TO prEN 10077-2

Theory

The thermal transmittance of a frame according to PrEN 10077-2:

$$U_f = \frac{L_{2D} - U_p * l_p}{l_f} \quad \text{and} \quad L_{2D} = \frac{q_{l,tot}}{\Delta \theta}$$

- with:
- U_f : thermal transmittance of the window frame [W/m²K]
 - U_p : thermal transmittance of the flanking panel [W/m²K]
 - l_p : projected width of the flanking panel [m]
 - l_f : projected width of the window frame [m]
 - L_{2D} : two-dimensional coupling coefficient [W/mK]
 - $q_{l,tot}$: total heat flow through the window frame and the flanking panel [W/m]
 - $\Delta \theta$: temperature difference between inside (θ_i) and outside (θ_e) [K]

Calculation	Item:		
input data:	$q_{l,tot} = 11,300$ W/m	$R_{se} = 0,04$ m ² K/W	
	$\theta_e = 0,0$ °C	$R_{si} = 0,13$ m ² K/W	
	$\theta_i = 20,0$ °C		
	$d_i = 0,0280$ m		
	$\lambda_i = 0,035$ W/m*K		
	$U_p = 1,031$ W/m ² K		
	$l_p = 0,190$ m		
	calculation results:	$L_{2D} = 0,57$ W/mK	
	$l_f = 0,1083$ m	$U_f = 3,41$ W/m ² K	
input data using the Physibel Software BISCO			

- $q_{l,tot}$: alphanumeric output BISCO
heat losses per boundary condition
- $\Delta \theta$: input data, surface boundary conditions:
inside temperature minus outside temperature
- U_p : calculation, using the following formula:

$$U_p = \left[\frac{1}{h_e} + \sum \frac{d_i}{\lambda_i} + \frac{1}{h_i} \right]^{-1}$$

- with: h_e / h_i ext./int. surface heat transfer coeff. [W/m²K]
- d_i thickness of layer i [m]
- λ_i thermal conductivity of layer i [W/mK]
- l_p / l_f : input data: dimensions of the item

PHYSIBEL Heirweg 21 B-9990 Maldegem Belgium tel +32 50 711432 fax +32 50 717842



Isotermas

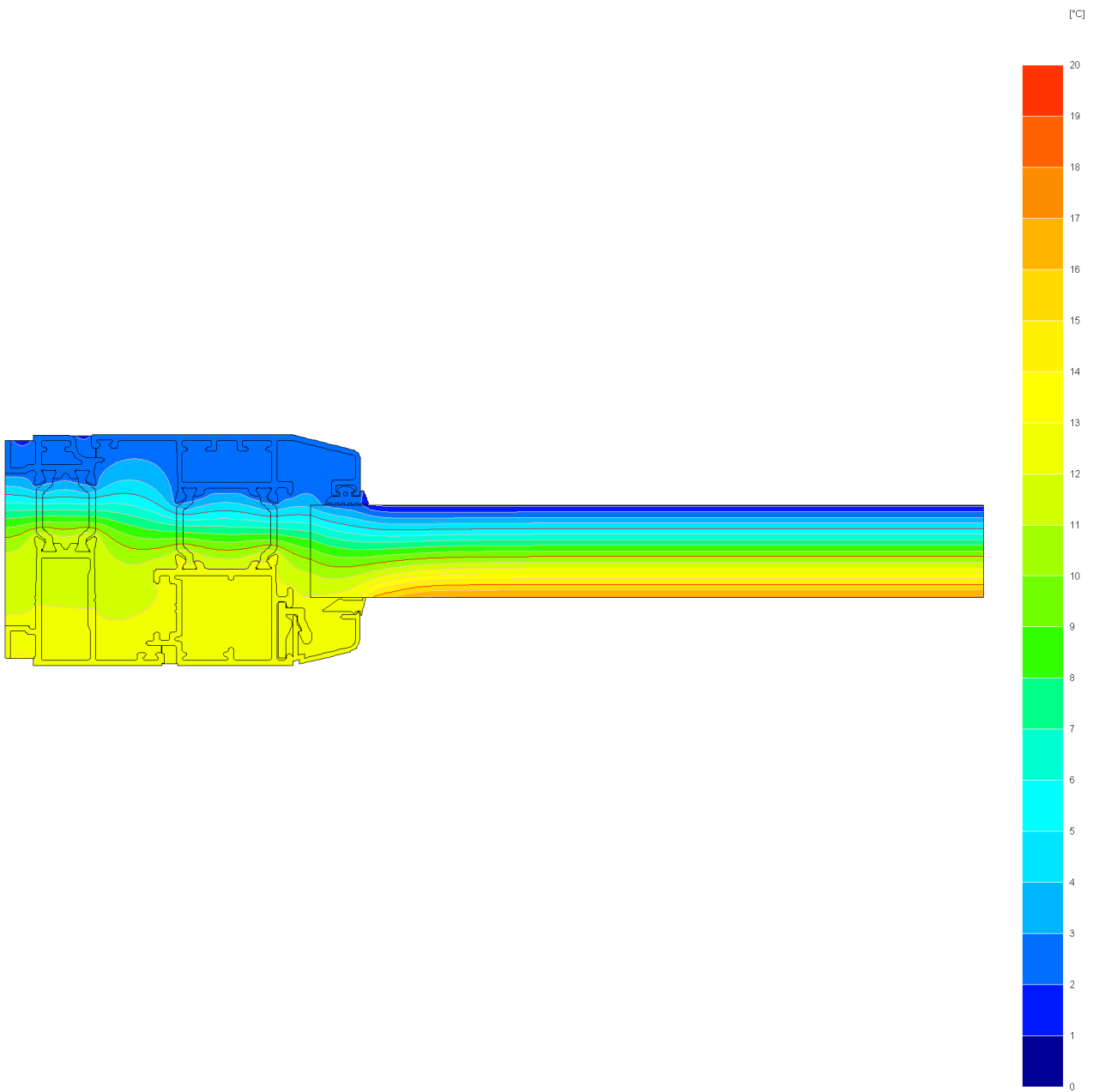



Flujo de calor

[W/m]

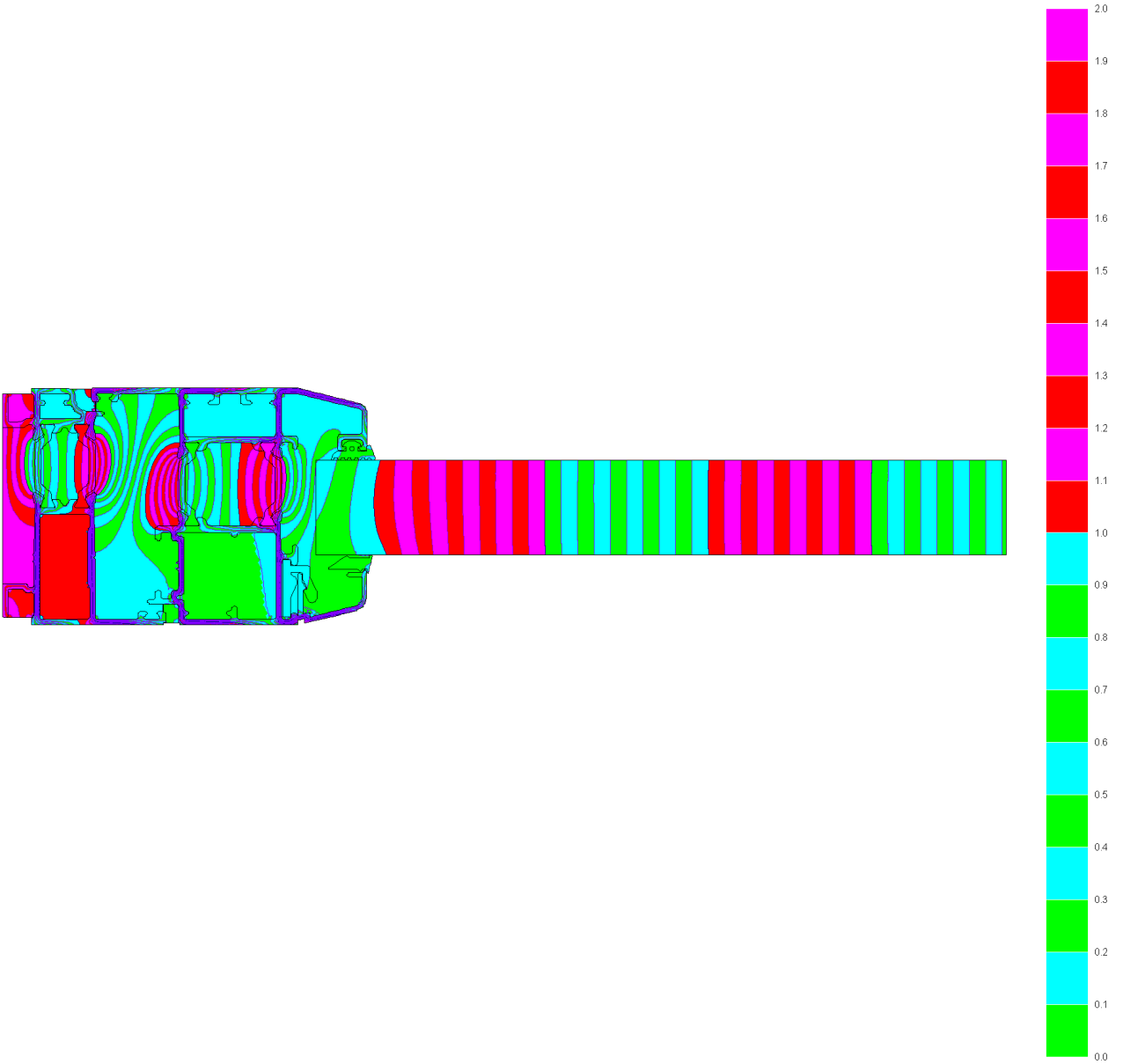



B) mediante RADCON con “Know-How” TECHNOFORM

Input – data RADCON

Col.	Name	Type	CEN-rule	Coupled	lambda [W/mK]	eps [-]	t [°C]	h [W/m²K]
8	aluminium	MATERIAL			160.000	0.90		
28	insulation	MATERIAL			0.035	0.90		
44	polyamid reinf.	MATERIAL			0.300	0.90		
60	EPDM	MATERIAL			0.250	0.90		
119	temp. sensor 1	MATERIAL			160.000	0.90		
135	temp. sensor 2	MATERIAL			160.000	0.90		
151	temp. sensor 3	MATERIAL			160.000	0.90		
156	insulation far	MATERIAL			0.035	0.90		
170	exterior	BC_SKY	NIHIL					
174	interior 1	BC_SKY	NIHIL					
182	interior 2	BC_SKY	NIHIL					
190	interior 3	BC_SKY	NIHIL					
214	cavity	BC_FREE	CEN_VF_I	NO				
215	cavity	EQUIMAT	CEN_VF_I	NO	0.044	0.90		
216	cavity	BC_FREE	CEN_VF_I	NO				
217	cavity	BC_FREE	CEN_VF_I	NO				
218	cavity	BC_FREE	CEN_VF_I	NO				
219	cavity	EQUIMAT	CEN_VF_I	NO	0.064	0.90		
220	cavity	BC_FREE	CEN_VF_I	NO				
221	cavity	BC_FREE	CEN_VF_I	NO				
222	cavity	BC_FREE	CEN_VF_I	NO				
240	cavity	EQUIMAT	CEN_VF_E	NO	0.093	0.90		
241	cavity	EQUIMAT	CEN_VF_E	NO	0.100	0.90		
242	cavity	EQUIMAT	CEN_VF_E	NO	0.080	0.90		
243	cavity	EQUIMAT	CEN_VF_E	NO	0.081	0.90		
250	cavity <4x4 mm2	MATERIAL			0.037	0.90		
252	cavity <2x2 mm2	MATERIAL			0.031	0.90		
253	cavity <1x1 mm2	MATERIAL			0.028	0.90		



Col.	q [W/m ²]	ta [°C]	hc [W/m ² K]	qc [W/m]	tr [°C]	C1 [-]	C2 [-]	C3 [-]
8								
28								
44								
60								
119								
135								
151								
156								
170	0	0.0	12.00		0.0			
174	0	20.0	2.33		20.0			
182	0	20.0	2.50		20.0			
190	0	20.0	2.98		20.0			
214	0		2.02	0		0.0247	0.58	0.25
215						0.0244	0.58	0.25
216	0		2.47	0		0.0247	0.58	0.25
217	0		1.64	0		0.0251	0.58	0.25
218	0		2.03	0		0.0247	0.58	0.25
219						0.0243	0.58	0.25
220	0		2.19	0		0.0247	0.58	0.25
221	0		2.04	0		0.0251	0.58	0.25
222	0		2.49	0		0.0248	0.58	0.333333
240						0.0243	0.58	0.25
241						0.0252	0.58	0.25
242						0.0243	0.58	0.25
243						0.0251	0.58	0.25
250								
252								
253								

Calculation parameters

Contour approximation margin (triangulation) = 0 pixels

Iteration cycles = 5

Nonlinear radiation

Recalculation of CEN values (before each iteration cycle)

Smallest accepted viewfactor = 0.001

Number of visibility rays between radiative surfaces = 100

Black radiation heat transfer coeff. (linear radiation) = 5.25 W/m²K

Maximum number of iterations (per iteration cycle) = 10000

Maximum temperature difference = 0.0001°C

Max. heat flow divergence for total object = 0.001 %

Max. heat flow divergence for any node = 1 %



Output – data RADCON

Col.	Name	Type	tmin [°C]	tmax [°C]	ta [°C]	flow in [W/m]	flow out [W/m]
8	aluminium	MATERIAL	3.35	13.04			
28	insulation	MATERIAL	1.32	16.60			
44	polyamid reinf.	MATERIAL	3.52	12.81			
60	EPDM	MATERIAL	2.65	13.42			
119	temp. sensor 1	MATERIAL	12.87	12.87			
135	temp. sensor 2	MATERIAL	12.97	12.97			
151	temp. sensor 3	MATERIAL	15.90	15.90			
156	insulation far	MATERIAL	1.24	17.29			
170	exterior	BC_SKY	1.24	3.59		0.00	10.69
174	interior 1	BC_SKY	16.61	17.29		3.50	0.00
182	interior 2	BC_SKY	13.04	16.61		1.05	0.00
190	interior 3	BC_SKY	12.85	14.06		6.14	0.00
214	cavity	BC_FREE	3.59	12.84	9.69	0.69	0.69
215	cavity	EQUIMAT	3.57	3.60			
216	cavity	BC_FREE	3.60	12.76	8.36	0.61	0.61
217	cavity	BC_FREE	12.76	12.87	12.81	0.01	0.01
218	cavity	BC_FREE	3.48	12.90	9.34	1.97	1.97
219	cavity	EQUIMAT	3.43	3.54			
220	cavity	BC_FREE	3.53	12.80	8.24	1.19	1.19
221	cavity	BC_FREE	12.79	12.97	12.88	0.03	0.03
222	cavity	BC_FREE	3.36	13.30	8.92	1.71	1.71
240	cavity	EQUIMAT	2.42	3.60			
241	cavity	EQUIMAT	12.83	14.06			
242	cavity	EQUIMAT	2.54	3.59			
243	cavity	EQUIMAT	12.89	13.79			
250	cavity <4x4 mm2	MATERIAL	12.77	12.99			
252	cavity <2x2 mm2	MATERIAL	3.20	3.68			
253	cavity <1x1 mm2	MATERIAL	2.86	13.15			



Cálculo del coeficiente de transmisión térmica (Uf)

THERMAL TRANSMITTANCE ACCORDING TO prEN 10077-2

Theory

The thermal transmittance of a frame according to PrEN 10077-2:

$$U_f = \frac{L_{2D} - U_p * l_p}{l_f} \quad \text{and} \quad L_{2D} = \frac{q_{l,tot}}{\Delta \theta}$$

- with:
- U_f : thermal transmittance of the window frame [W/m²K]
 - U_p : thermal transmittance of the flanking panel [W/m²K]
 - l_p : projected width of the flanking panel [m]
 - l_f : projected width of the window frame [m]
 - L_{2D} : two-dimensional coupling coefficient [W/mK]
 - $q_{l,tot}$: total heat flow through the window frame and the flanking panel [W/m]
 - $\Delta\theta$: temperature difference between inside (θ_i) and outside (θ_e) [K]

Calculation	Item:		
input data:	$q_{l,tot} = 10,690$ W/m	$R_{se} = 0,06$ m ² K/W	
	$\theta_e = 0,0$ °C	$R_{si} = 0,13$ m ² K/W	
	$\theta_i = 20,0$ °C		
	$d_i = 0,0280$ m		
	$\lambda_i = 0,035$ W/m*K		
	$U_p = 1,010$ W/m ² K		
	$l_p = 0,190$ m		
	calculation results:	$L_{2D} = 0,53$ W/mK	
	$l_f = 0,1083$ m	$U_f = 3,16$ W/m ² K	

input data using the Physibel Software BISCO

- $q_{l,tot}$: alphanumeric output BISCO
heat losses per boundary condition
- $\Delta\theta$: input data, surface boundary conditions:
inside temperature minus outside temperature
- U_p : calculation, using the following formula:

$$U_p = \left[\frac{1}{h_e} + \sum \frac{d_i}{\lambda_i} + \frac{1}{h_i} \right]^{-1}$$

- with: h_e / h_i ext./int. surface heat transfer coeff. [W/m²K]
- d_i thickness of layer i [m]
- λ_i thermal conductivity of layer i [W/mK]
- l_p / l_f : input data: dimensions of the item

PHYSIBEL Heirweg 21 B-9990 Maldegem Belgium tel +32 50 711432 fax +32 50 717842