



Cálculo del coeficiente de transmisión térmica (Uf)

Ventana de Rebatir de 2 hojas M-Tres (Encuentro central), con Poliamida de 25

Cliente:

Alcemar

Cálculos realizados por

Technoform BAUTEC Ibérica, s.l.

Laia Cardona

Tel: +34 93 238 64 38/ Fax: +34 93 415 40 37

Email: tb-es@technoform.es

Fecha:

24.04.2006

Resultados

<p>Puerta de rebatir RPT M-3\25 mediante BISCO según norma EN ISO 10077-2:2003</p>	<p>Uf = 3,31 W/m²K</p>
<p>Puerta de rebatir RPT M-3\25 mediante RADCON con "Know-How" TECHNOFORM</p>	<p>Uf = 3,04 W/m²K</p>

En este informe se determina el coeficiente de transmisión térmica (Uf) mediante dos métodos de cálculo diferentes:

- A) Aplicando la norma EN ISO 10077-2:2003, y usando el software "BISCO" de la empresa Physibel.
- B) Aplicando un método propio, "know-how" de Technoform, donde se usa el software "RADCON"- también propiedad de Physibel - y el valor final equivale aproximadamente al resultado en el test de cálculo de nuestra HOT-BOX (La diferencia es de un 5%) según norma ISO/FDIS 12567:2000.

Contenido

- **Dibujo sistema**

- A) mediante BISCO según norma EN ISO 10077-2:2003**

- **Input – data BISCO**
- **Output – data BISCO**
- **Cálculo del coeficiente de transmisión térmica (U_f)**
- **Isotermas**
- **Flujo de calor**

- B) mediante RADCON con “Know-How” TECHNOFORM**

- **Input – data RADCON**
- **Output – data RADCON**
- **Cálculo del coeficiente de transmisión térmica (U_f)**

Dibujo sistema

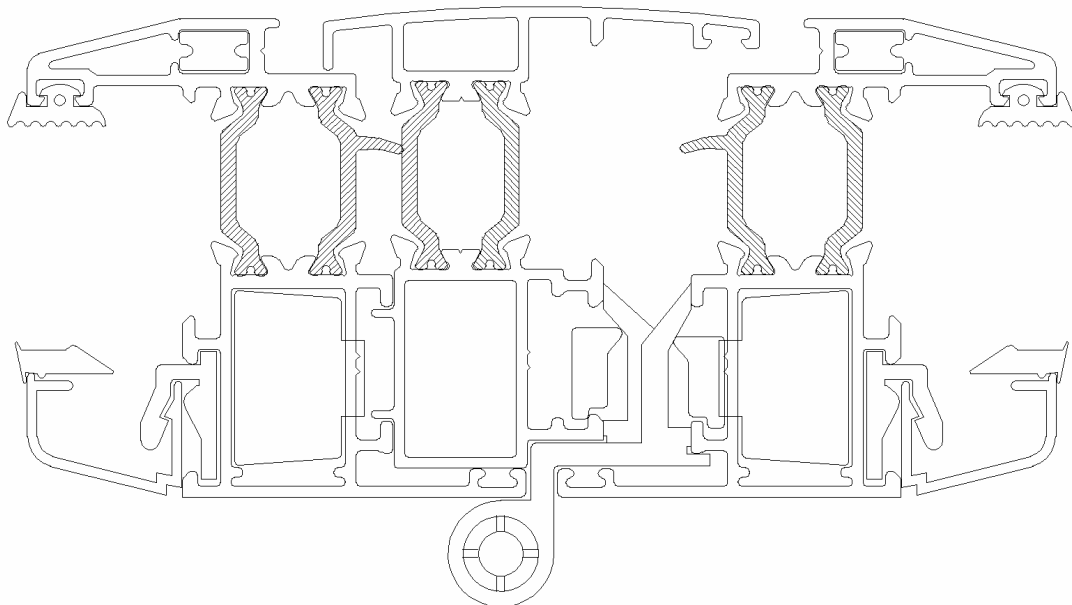



A) mediante BISCO según norma EN ISO 10077-2:2003

Input – data BISCO

Col.	Name	Type	CEN-rule	Coupled	lambda [W/mK]	eps [-]	t [°C]	h [W/m²K]
8	aluminium	MATERIAL			160.000			
24	aluminium	MATERIAL			160.000			
28	insulation	MATERIAL			0.040			
52	PCP	MATERIAL			0.230			
60	EPDM	MATERIAL			0.250			
119	temp. sensor 1	MATERIAL			160.000			
135	temp. sensor 2	MATERIAL			160.000			
151	temp. sensor 3	MATERIAL			160.000			
167	temp. sensor 4	MATERIAL			160.000			
170	exterior	BC_SIMPL	HE				0.0	25.00
174	interior (norma	BC_SIMPL	HI_NORML				20.0	7.70
182	interior (reduc	BC_SIMPL	HI_REDUC				20.0	5.00
214	cavity (CEN)	EQUIMAT	CEN_VF_I	NO	0.042			
215	cavity (CEN)	EQUIMAT	CEN_VF_I	NO	0.138			
216	cavity (CEN)	EQUIMAT	CEN_VF_I	NO	0.084			
217	cavity (CEN)	EQUIMAT	CEN_VF_I	NO	0.095			
218	cavity (CEN)	EQUIMAT	CEN_VF_I	NO	0.054			
219	cavity (CEN)	EQUIMAT	CEN_VF_I	NO	0.057			
220	cavity (CEN)	EQUIMAT	CEN_VF_I	NO	0.069			
221	cavity (CEN)	EQUIMAT	CEN_VF_I	NO	0.039			
222	cavity (CEN)	EQUIMAT	CEN_VF_I	NO	0.046			
223	cavity (CEN)	EQUIMAT	CEN_VF_I	NO	0.075			
224	cavity (CEN)	EQUIMAT	CEN_VF_I	NO	0.089			
225	cavity (CEN)	EQUIMAT	CEN_VF_I	NO	0.217			
226	cavity (CEN)	EQUIMAT	CEN_VF_I	NO	0.096			
227	cavity (CEN)	EQUIMAT	CEN_VF_I	NO	0.042			
228	cavity (CEN)	EQUIMAT	CEN_VF_I	NO	0.139			
235	cavity (CEN)	EQUIMAT	CEN_VF_I	NO	0.084			
240	cavity (CEN)	EQUIMAT	CEN_VF_E	NO	0.071			
241	cavity (CEN)	EQUIMAT	CEN_VF_E	NO	0.087			
250	cavity <4x4 mm2	MATERIAL			0.037			
251	cavity <3x3 mm2	MATERIAL			0.034			
252	cavity <2x2 mm2	MATERIAL			0.031			
253	cavity <1x1 mm2	MATERIAL			0.028			

Col.	q [W/m²]	ta [°C]	hc [W/m²K]	qc [W/m]	tr [°C]	C1 [-]	C2 [-]	C3 [-]
8								
24								
28								
52								
60								
119								
135								
151								
167								
170	0							
174	0							



182	0			
214		0.025	0.73	0.333333
215		0.025	0.73	0.333333
216		0.025	0.73	0.333333
217		0.025	0.73	0.333333
218		0.025	0.73	0.333333
219		0.025	0.73	0.333333
220		0.025	0.73	0.333333
221		0.025	0.73	0.333333
222		0.025	0.73	0.333333
223		0.025	0.73	0.333333
224		0.025	0.73	0.333333
225		0.025	0.73	0.333333
226		0.025	0.73	0.333333
227		0.025	0.73	0.333333
228		0.025	0.73	0.333333
235		0.025	0.73	0.333333
240		0.025	0.73	0.333333
241		0.025	0.73	0.333333
250				
251				
252				
253				

Calculation parameters

Contour approximation margin (triangulation) = 0 pixels
 Iteration cycles = 5
 Recalculation of CEN values (before each iteration cycle)
 Maximum number of iterations (per iteration cycle) = 10000
 Maximum temperature difference = 0.0001°C
 Max. heat flow divergence for total object = 0.001 %
 Max. heat flow divergence for any node = 1 %



Output – data BISCO

Col.	Name	Type	tmin [°C]	tmax [°C]	ta [°C]	flow in [W/m]	flow out [W/m]
8	aluminium	MATERIAL	2.06	13.54			
24	aluminium	MATERIAL	2.06	13.42			
28	insulation	MATERIAL	0.89	17.06			
52	PCP	MATERIAL	2.12	13.24			
60	EPDM	MATERIAL	1.55	14.07			
119	temp. sensor 1	MATERIAL	15.20	15.20			
135	temp. sensor 2	MATERIAL	12.75	12.75			
151	temp. sensor 3	MATERIAL	13.41	13.41			
167	temp. sensor 4	MATERIAL	15.51	15.51			
170	exterior	BC_SIMPL	0.89	2.57		0.00	12.87
174	interior (norma	BC_SIMPL	12.67	17.06		11.19	0.00
182	interior (reduc	BC_SIMPL	12.87	16.36		1.69	0.00
214	cavity (CEN)	EQUIMAT	2.06	2.12			
215	cavity (CEN)	EQUIMAT	2.09	13.52			
216	cavity (CEN)	EQUIMAT	2.13	12.59			
217	cavity (CEN)	EQUIMAT	12.59	12.75			
218	cavity (CEN)	EQUIMAT	2.14	4.89			
219	cavity (CEN)	EQUIMAT	4.80	12.59			
220	cavity (CEN)	EQUIMAT	12.59	12.66			
221	cavity (CEN)	EQUIMAT	12.65	12.69			
222	cavity (CEN)	EQUIMAT	2.15	2.19			
223	cavity (CEN)	EQUIMAT	2.19	12.56			
224	cavity (CEN)	EQUIMAT	12.55	12.67			
225	cavity (CEN)	EQUIMAT	2.12	13.42			
226	cavity (CEN)	EQUIMAT	13.23	13.42			
227	cavity (CEN)	EQUIMAT	2.52	2.60			
228	cavity (CEN)	EQUIMAT	2.56	13.98			
235	cavity (CEN)	EQUIMAT	2.61	13.23			
240	cavity (CEN)	EQUIMAT	1.19	2.63			
241	cavity (CEN)	EQUIMAT	12.65	13.87			
250	cavity <4x4 mm2	MATERIAL	12.64	13.45			
251	cavity <3x3 mm2	MATERIAL	2.07	13.45			
252	cavity <2x2 mm2	MATERIAL	2.10	13.30			
253	cavity <1x1 mm2	MATERIAL	1.67	13.60			



Cálculo del coeficiente de transmisión térmica (Uf)

THERMAL TRANSMITTANCE ACCORDING TO prEN 10077-2

Theory

The thermal transmittance of a frame according to PrEN 10077-2:

$$U_f = \frac{L_{2D} - U_p * l_p}{l_f} \quad \text{and} \quad L_{2D} = \frac{q_{l,tot}}{\Delta \theta}$$

- with:
- U_f : thermal transmittance of the window frame [W/m²K]
 - U_p : thermal transmittance of the flanking panel [W/m²K]
 - l_p : projected width of the flanking panel [m]
 - l_f : projected width of the window frame [m]
 - L_{2D} : two-dimensional coupling coefficient [W/mK]
 - $q_{l,tot}$: total heat flow through the window frame and the flanking panel [W/m]
 - $\Delta \theta$: temperature difference between inside (θ_i) and outside (θ_e) [K]

Calculation	Item:		
input data:	$q_{l,tot} =$	12,87 W/m	$R_{se} =$ 0,04 m ² K/W
	$\theta_e =$	0,0 °C	$R_{si} =$ 0,13 m ² K/W
	$\theta_i =$	20,0 °C	
	$d_i =$	0,0280 m	
	$\lambda_i =$	0,035 W/m*K	
	$U_p =$	1,031 W/m ² K	
	$l_p =$	0,190 m	
	calculation results:	$L_{2D} =$ 0,64 W/mK	
	$l_f =$	0,1353 m	$U_f =$ 3,31 W/m ² K

input data using the Physibel Software BISCO

- $q_{l,tot}$: alphanumeric output BISCO
- heat losses per boundary condition
- $\Delta \theta$: input data, surface boundary conditions:
inside temperature minus outside temperature
- U_p : calculation, using the following formula:

$$U_p = \left[\frac{1}{h_e} + \sum \frac{d_i}{\lambda_i} + \frac{1}{h_i} \right]^{-1}$$

- with: h_e / h_i ext./int. surface heat transfer coeff. [W/m²K]
- d_i thickness of layer i [m]
- λ_i thermal conductivity of layer i [W/mK]

- l_p / l_f : input data: dimensions of the item

PHYSIBEL Heirweg 21 B-9990 Maldegem Belgium tel +32 50 711432 fax +32 50 717842



Isotermas

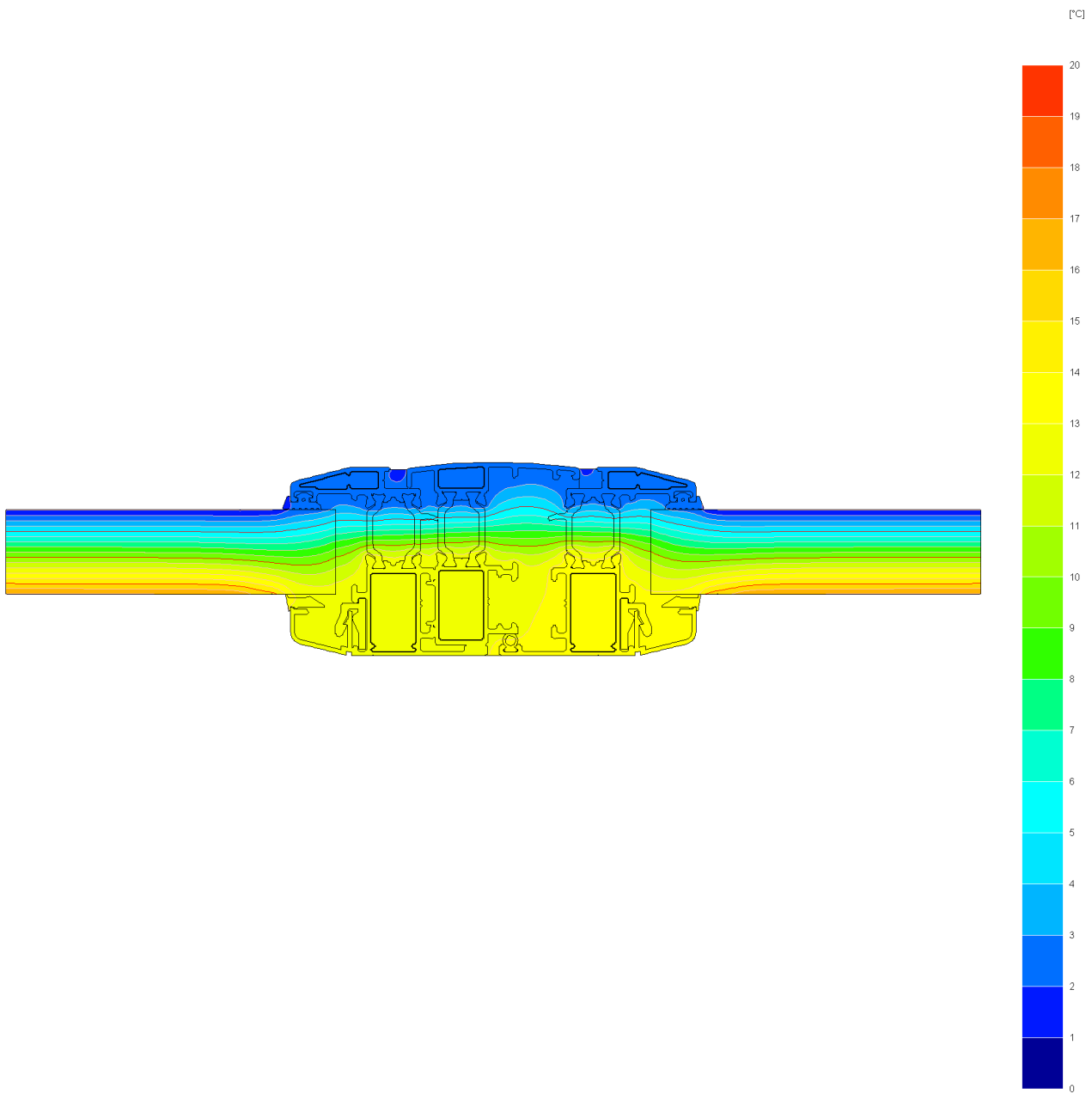



Flujo de calor

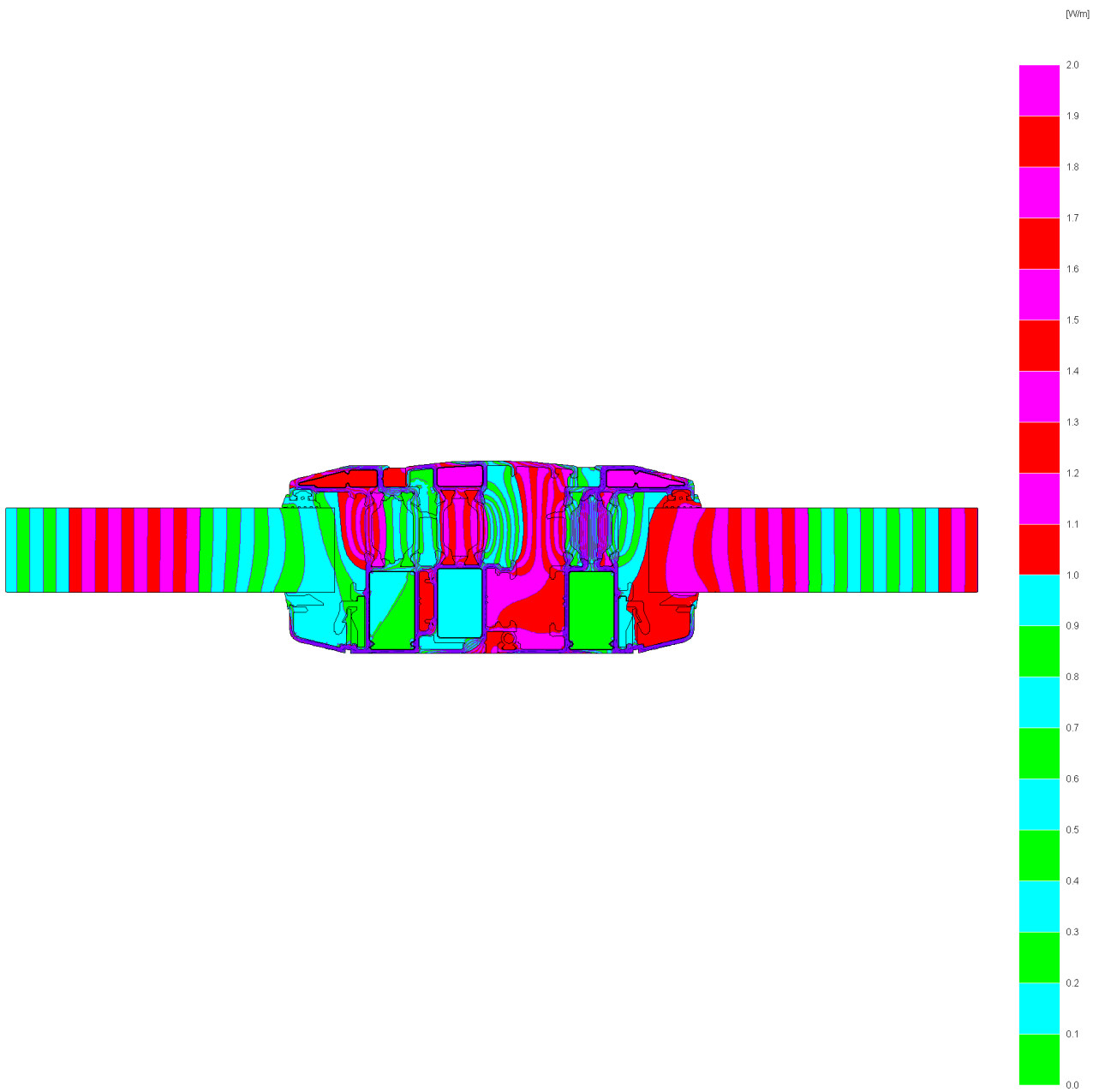



B) mediante RADCON con “Know-How” TECHNOFORM

Input – data RADCON

Col.	Name	Type	CEN-rule	Coupled	lambda [W/mK]	eps [-]	t [°C]	h [W/m²K]
8	aluminium	MATERIAL			160.000	0.90		
24	aluminium epsil	MATERIAL			160.000	0.30		
28	insulation	MATERIAL			0.035	0.90		
52	PCP	MATERIAL			0.230	0.90		
60	EPDM	MATERIAL			0.250	0.90		
119	temp. sensor 1	MATERIAL			160.000	0.90		
135	temp. sensor 2	MATERIAL			160.000	0.90		
151	temp. sensor 3	MATERIAL			160.000	0.90		
156	insulation far	MATERIAL			0.035	0.90		
167	temp. sensor 4	MATERIAL			160.000	0.90		
170	exterior	BC_SKY	NIHIL					
174	interior 1	BC_SKY	NIHIL					
182	interior 2	BC_SKY	NIHIL					
190	interior 3	BC_SKY	NIHIL					
214	cavity	EQUIMAT	CEN_VF_I	NO	0.042	0.90		
215	cavity	EQUIMAT	CEN_VF_I	NO	0.127	0.90		
216	cavity	BC_FREE	CEN_VF_I	NO				
217	cavity	BC_FREE	CEN_VF_I	NO				
218	cavity	EQUIMAT	CEN_VF_I	NO	0.056	0.90		
219	cavity	EQUIMAT	CEN_VF_I	NO	0.058	0.90		
220	cavity	EQUIMAT	CEN_VF_I	NO	0.068	0.90		
221	cavity	EQUIMAT	CEN_VF_I	NO	0.039	0.90		
222	cavity	EQUIMAT	CEN_VF_I	NO	0.047	0.90		
223	cavity	EQUIMAT	CEN_VF_I	NO	0.073	0.90		
224	cavity	BC_FREE	CEN_VF_I	NO				
225	cavity	EQUIMAT	CEN_VF_I	NO	0.200	0.90		
226	cavity	BC_FREE	CEN_VF_I	NO				
227	cavity	EQUIMAT	CEN_VF_I	NO	0.042	0.90		
228	cavity	EQUIMAT	CEN_VF_I	NO	0.128	0.90		
235	cavity	EQUIMAT	CEN_VF_I	NO	0.078	0.90		
240	cavity	EQUIMAT	CEN_VF_E	NO	0.072	0.90		
241	cavity	EQUIMAT	CEN_VF_E	NO	0.086	0.90		
250	cavity <4x4 mm2	MATERIAL			0.037	0.90		
251	cavity <3x3 mm2	MATERIAL			0.034	0.90		
252	cavity <2x2 mm2	MATERIAL			0.031	0.90		
253	cavity <1x1 mm2	MATERIAL			0.028	0.90		

Col.	q [W/m²]	ta [°C]	hc [W/m²K]	qc [W/m]	tr [°C]	C1 [-]	C2 [-]	C3 [-]
8								
24								
28								
52								
60								
119								
135								
151								
156								



167							
170	0	0.0	12.00		0.0		
174	0	20.0	2.33		20.0		
182	0	20.0	2.65		20.0		
190	0	20.0	2.88		20.0		
214					0.0243	0.58	0.25
215					0.0248	0.58	0.333333
216	0		2.50	0	0.0247	0.58	0.333333
217	0		2.06	0	0.0252	0.58	0.25
218					0.0245	0.58	0.25
219					0.0249	0.58	0.25
220					0.0252	0.58	0.25
221					0.0252	0.58	0.25
222					0.0243	0.58	0.25
223					0.0247	0.58	0.333333
224	0		2.20	0	0.0252	0.58	0.25
225					0.0247	0.58	0.333333
226	0		2.06	0	0.0252	0.58	0.25
227					0.0244	0.58	0.25
228					0.0248	0.58	0.333333
235					0.0248	0.58	0.333333
240					0.0243	0.58	0.25
241					0.0252	0.58	0.25
250							
251							
252							
253							

Calculation parameters

Contour approximation margin (triangulation) = 0 pixels

Iteration cycles = 5

Nonlinear radiation

Recalculation of CEN values (before each iteration cycle)

Smallest accepted viewfactor = 0.001

Number of visibility rays between radiative surfaces = 100

Black radiation heat transfer coeff. (linear radiation) = 5.25 W/m²K

Maximum number of iterations (per iteration cycle) = 10000

Maximum temperature difference = 0.0001°C

Max. heat flow divergence for total object = 0.001 %

Max. heat flow divergence for any node = 1 %



Output – data RADCON

Col.	Name	Type	tmin [°C]	tmax [°C]	ta [°C]	flow in [W/m]	flow out [W/m]
8	aluminium	MATERIAL	3.16	13.94			
24	aluminium epsil	MATERIAL	3.16	13.86			
28	insulation	MATERIAL	1.26	16.76			
52	PCP	MATERIAL	3.22	13.74			
60	EPDM	MATERIAL	2.54	14.33			
119	temp. sensor 1	MATERIAL	15.79	15.79			
135	temp. sensor 2	MATERIAL	13.23	13.23			
151	temp. sensor 3	MATERIAL	13.86	13.86			
156	insulation far	MATERIAL	1.21	17.31			
167	temp. sensor 4	MATERIAL	16.12	16.12			
170	exterior	BC_SKY	1.21	3.70		0.00	12.06
174	interior 1	BC_SKY	16.68	17.31		3.21	0.00
182	interior 2	BC_SKY	13.32	16.76		2.01	0.00
190	interior 3	BC_SKY	13.17	14.34		6.84	0.00
214	cavity	EQUIMAT	3.16	3.22			
215	cavity	EQUIMAT	3.20	13.82			
216	cavity	BC_FREE	3.22	13.11	8.30	0.65	0.65
217	cavity	BC_FREE	13.11	13.23	13.16	0.01	0.01
218	cavity	EQUIMAT	3.23	6.88			
219	cavity	EQUIMAT	6.90	13.11			
220	cavity	EQUIMAT	13.11	13.16			
221	cavity	EQUIMAT	13.16	13.19			
222	cavity	EQUIMAT	3.23	3.27			
223	cavity	EQUIMAT	3.27	13.08			
224	cavity	BC_FREE	13.08	13.17	13.13	0.00	0.00
225	cavity	EQUIMAT	3.23	13.86			
226	cavity	BC_FREE	13.74	13.86	13.80	0.01	0.01
227	cavity	EQUIMAT	3.66	3.73			
228	cavity	EQUIMAT	3.69	14.24			
235	cavity	EQUIMAT	3.73	13.74			
240	cavity	EQUIMAT	2.11	3.86			
241	cavity	EQUIMAT	13.15	14.34			
250	cavity <4x4 mm2	MATERIAL	13.15	13.89			
251	cavity <3x3 mm2	MATERIAL	3.17	13.88			
252	cavity <2x2 mm2	MATERIAL	3.21	13.78			
253	cavity <1x1 mm2	MATERIAL	2.66	14.01			



Cálculo del coeficiente de transmisión térmica (Uf)

THERMAL TRANSMITTANCE ACCORDING TO prEN 10077-2

Theory

The thermal transmittance of a frame according to PrEN 10077-2:

$$U_f = \frac{L_{2D} - U_p * l_p}{l_f} \quad \text{and} \quad L_{2D} = \frac{q_{l,tot}}{\Delta \theta}$$

- with:
- U_f : thermal transmittance of the window frame [W/m²K]
 - U_p : thermal transmittance of the flanking panel [W/m²K]
 - l_p : projected width of the flanking panel [m]
 - l_f : projected width of the window frame [m]
 - L_{2D} : two-dimensional coupling coefficient [W/mK]
 - $q_{l,tot}$: total heat flow through the window frame and the flanking panel [W/m]
 - $\Delta \theta$: temperature difference between inside (θ_i) and outside (θ_e) [K]

Calculation	Item:		
input data:	$q_{l,tot} =$	12,06 W/m	$R_{se} =$ 0,06 m ² K/W
	$\theta_e =$	0,0 °C	$R_{si} =$ 0,13 m ² K/W
	$\theta_i =$	20,0 °C	
	$d_i =$	0,0280 m	
	$\lambda_i =$	0,035 W/m*K	
	$U_p =$	1,010 W/m ² K	
	$l_p =$	0,190 m	
	calculation results:		$L_{2D} =$ 0,60 W/mK
	$l_f =$	0,1353 m	$U_f =$ 3,04 W/m ² K

input data using the Physibel Software BISCO

- $q_{l,tot}$: alphanumeric output BISCO
heat losses per boundary condition
- $\Delta \theta$: input data, surface boundary conditions:
inside temperature minus outside temperature
- U_p : calculation, using the following formula:

$$U_p = \left[\frac{1}{h_e} + \sum \frac{d_i}{\lambda_i} + \frac{1}{h_i} \right]^{-1}$$

- with: h_e / h_i ext./int. surface heat transfer coeff. [W/m²K]
- d_i thickness of layer i [m]
- λ_i thermal conductivity of layer i [W/mK]

- l_p / l_f : input data: dimensions of the item

PHYSIBEL Heirweg 21 B-9990 Maldegem Belgium tel +32 50 711432 fax +32 50 717842