



Cálculo del coeficiente de transmisión térmica (Uf)

Ventana y Puerta Corrediza M-Tres (Encuentro central), con Poliamida de 15 - Mediterránea RPT

Cliente:

Alcemar

Cálculos realizados por

Technoform BAUTEC Ibérica, s.l.

Laia Cardona

Tel: +34 93 238 64 38/ Fax: +34 93 415 40 37

Email: tb-es@technoform.es

24.04.2006

Fecha:

Resultados

Encuentro de hojas Corredera RPT M-3 mediante BISCO según norma EN ISO 10077-2:2003	Uf = 5,84 W/m ² K
Encuentro de hojas Corredera RPT M-3 mediante RADCON con "Know-How" TECHNOFORM	Uf = 4,90 W/m ² K

En este informe se determina el coeficiente de transmisión térmica (Uf) mediante dos métodos de cálculo diferentes:

A) Aplicando la norma EN ISO 10077-2:2003, y usando el software "BISCO" de la empresa Physibel.



B) Aplicando un método propio, “know-how” de Technoform, donde se usa el software “RADCON”- también propiedad de Physibel - y el valor final equivale aproximadamente al resultado en el test de cálculo de nuestra HOT-BOX (La diferencia es de un 5%) según norma ISO/FDIS 12567:2000.

Contenido

- Dibujo sistema

A) mediante BISCO según norma EN ISO 10077-2:2003

- Input – data BISCO
- Output – data BISCO
- Cálculo del coeficiente de transmisión térmica (U_f)
- Isotermas
- Flujo de calor

B) mediante RADCON con “Know-How” TECHNOFORM

- Input – data RADCON
- Output – data RADCON
- Cálculo del coeficiente de transmisión térmica (U_f)

Dibujo sistema

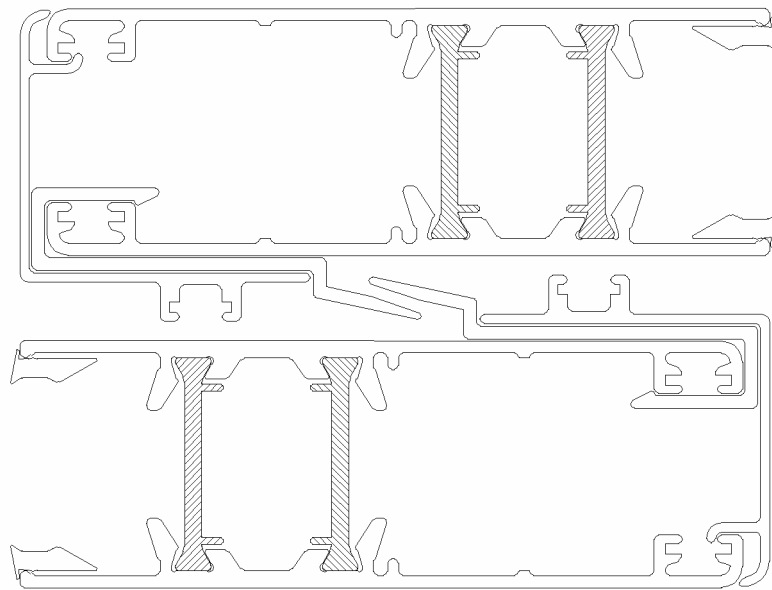

A) mediante BISCO según norma EN ISO 10077-2:2003

Input – data BISCO

Col.	Name	Type	CEN-rule	Coupled	lambda [W/mK]	eps [-]	t [°C]	h [W/m²K]
8	aluminium	MATERIAL			160.000			
28	insulation	MATERIAL			0.040			
36	polyamid nylon	MATERIAL			0.250			
44	polyamid reinf.	MATERIAL			0.300			
60	EPDM	MATERIAL			0.250			
67	PVC flexible	MATERIAL			0.140			
79	mohair sweep	MATERIAL			0.140			
119	temp. sensor 1	MATERIAL			160.000			
135	temp. sensor 2	MATERIAL			160.000			
151	temp. sensor 3	MATERIAL			160.000			
167	temp. sensor 4	MATERIAL			160.000			
170	exterior	BC_SIMPL	HE				0.0	25.00
174	interior (norma	BC_SIMPL	HI_NORML				20.0	7.70
182	interior (reduc	BC_SIMPL	HI_REduc				20.0	5.00
214	cavity (CEN)	EQUIMAT	CEN_VF_I	NO	0.093			
215	cavity (CEN)	EQUIMAT	CEN_VF_I	NO	0.083			
216	cavity (CEN)	EQUIMAT	CEN_VF_I	NO	0.061			
217	cavity (CEN)	EQUIMAT	CEN_VF_I	NO	0.063			
218	cavity (CEN)	EQUIMAT	CEN_VF_I	NO	0.089			
219	cavity (CEN)	EQUIMAT	CEN_VF_I	NO	0.108			



220	cavity (CEN)	EQUIMAT	CEN_VF_I	NO	0.054
240	cavity (CEN)	EQUIMAT	CEN_VF_E	NO	0.094
249	cavity <5x5 mm2	MATERIAL			0.040
250	cavity <4x4 mm2	MATERIAL			0.037
251	cavity <3x3 mm2	MATERIAL			0.034
252	cavity <2x2 mm2	MATERIAL			0.031
253	cavity <1x1 mm2	MATERIAL			0.028

Col.	q [W/m ²]	ta [°C]	hc [W/m ² K]	qc [W/m]	tr [°C]	C1 [-]	C2 [-]	C3 [-]
8								
28								
36								
44								
60								
67								
79								
119								
135								
151								
167								
170	0							
174	0							
182	0							
214						0.025	0.73	0.333333
215						0.025	0.73	0.333333
216						0.025	0.73	0.333333
217						0.025	0.73	0.333333
218						0.025	0.73	0.333333
219						0.025	0.73	0.333333
220						0.025	0.73	0.333333
240						0.025	0.73	0.333333
249								
250								
251								
252								
253								

Calculation parameters

Contour approximation margin (triangulation) = 0 pixels
 Iteration cycles = 5
 Recalculation of CEN values (before each iteration cycle)
 Maximum number of iterations (per iteration cycle) = 10000
 Maximum temperature difference = 0.0001°C
 Max. heat flow divergence for total object = 0.001 %
 Max. heat flow divergence for any node = 1 %

Output – data BISCO

Col.	Name	Type	tmin [°C]	tmax [°C]	ta [°C]	flow in [W/m]	flow out [W/m]
8	aluminium	MATERIAL	2.12	12.48			
28	insulation	MATERIAL	0.95	15.97			



36	polyamid nylon	MATERIAL	3.89	10.88		
44	polyamid reinf.	MATERIAL	2.16	12.43		
60	EPDM	MATERIAL	1.55	13.11		
67	PVC flexible	MATERIAL	3.19	11.44		
79	mohair sweep	MATERIAL	3.90	10.88		
119	temp. sensor 1	MATERIAL	14.24	14.24		
135	temp. sensor 2	MATERIAL	12.40	12.40		
151	temp. sensor 3	MATERIAL	11.93	11.93		
167	temp. sensor 4	MATERIAL	13.17	13.17		
170	exterior	BC_SIMPL	0.95	8.57	0.00	15.60
174	interior (norma	BC_SIMPL	11.83	15.97	10.16	0.00
182	interior (reduc	BC_SIMPL	5.46	15.17	5.44	0.00
214	cavity (CEN)	EQUIMAT	2.17	5.26		
215	cavity (CEN)	EQUIMAT	2.18	5.42		
216	cavity (CEN)	EQUIMAT	2.09	5.69		
217	cavity (CEN)	EQUIMAT	8.30	12.51		
218	cavity (CEN)	EQUIMAT	8.78	12.42		
219	cavity (CEN)	EQUIMAT	9.00	12.34		
220	cavity (CEN)	EQUIMAT	3.94	10.80		
240	cavity (CEN)	EQUIMAT	2.98	8.72		
249	cavity <5x5 mm2	MATERIAL	4.60	9.84		
250	cavity <4x4 mm2	MATERIAL	3.89	10.88		
251	cavity <3x3 mm2	MATERIAL	2.71	11.88		
252	cavity <2x2 mm2	MATERIAL	1.70	12.92		
253	cavity <1x1 mm2	MATERIAL	1.99	12.61		

Cálculo del coeficiente de transmisión térmica (Uf)

THERMAL TRANSMITTANCE ACCORDING TO prEN 10077-2

Theory

The thermal transmittance of a frame according to PrEN 10077-2:

$$U_f = \frac{L_{2D} - U_p * l_p}{l_f} \quad \text{and} \quad L_{2D} = \frac{q_{l,tot}}{\Delta \theta}$$

- with:
- U_f : thermal transmittance of the window frame [W/m²K]
 - U_p : thermal transmittance of the flanking panel [W/m²K]
 - l_p : projected width of the flanking panel [m]
 - l_f : projected width of the window frame [m]
 - L_{2D} : two-dimensional coupling coefficient [W/mK]
 - $q_{l,tot}$: total heat flow through the window frame and the flanking panel [W/m]
 - $\Delta \theta$: temperature difference between inside (θ_i) and outside (θ_e) [K]

Calculation	Item:		
input data:	$q_{l,tot} =$	15,60 W/m	$R_{se} =$ 0,04 m ² K/W
	$\theta_e =$	0,0 °C	$R_{si} =$ 0,13 m ² K/W
	$\theta_i =$	20,0 °C	
	$d_i =$	0,019 m	
	$\lambda_i =$	0,035 W/m*K	
	$U_p =$	1,405 W/m ² K	



$l_p = 0,190 \text{ m}$	calculation results:	$L_{2D} = 0,78 \text{ W/mK}$
$l_f = 0,0880 \text{ m}$		$U_f = 5,84 \text{ W/m}^2\text{K}$

input data using the Physibel Software BISCO

- $q_{l,tot}$: alphanumeric output BISCO
heat losses per boundary condition
- $\Delta\theta$: input data, surface boundary conditions:
inside temperature minus outside temperature
- U_p : calculation, using the following formula:

$$U_p = \left[\frac{1}{h_e} + \sum \frac{d_i}{\lambda_i} + \frac{1}{h_i} \right]^{-1}$$

- with: h_e / h_i ext./int. surface heat transfer coeff. [W/m²K]
- d_i thickness of layer i [m]
- λ_i thermal conductivity of layer i [W/mK]

l_p / l_f : input data: dimensions of the item

PHYSIBEL Heirweg 21 B-9990 Maldegem Belgium tel +32 50 711432 fax +32 50 717842



Isotermas

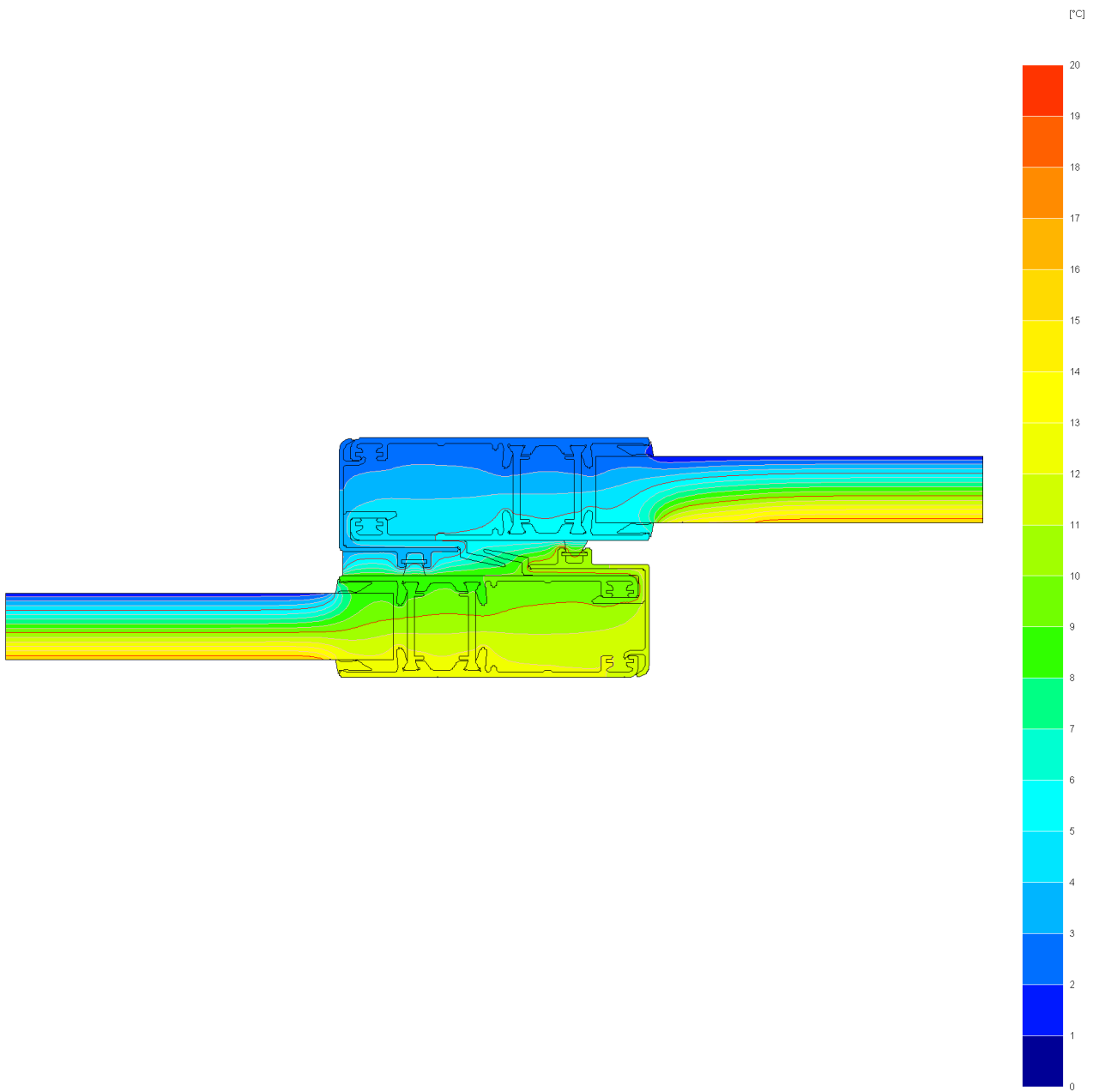



Flujo de calor

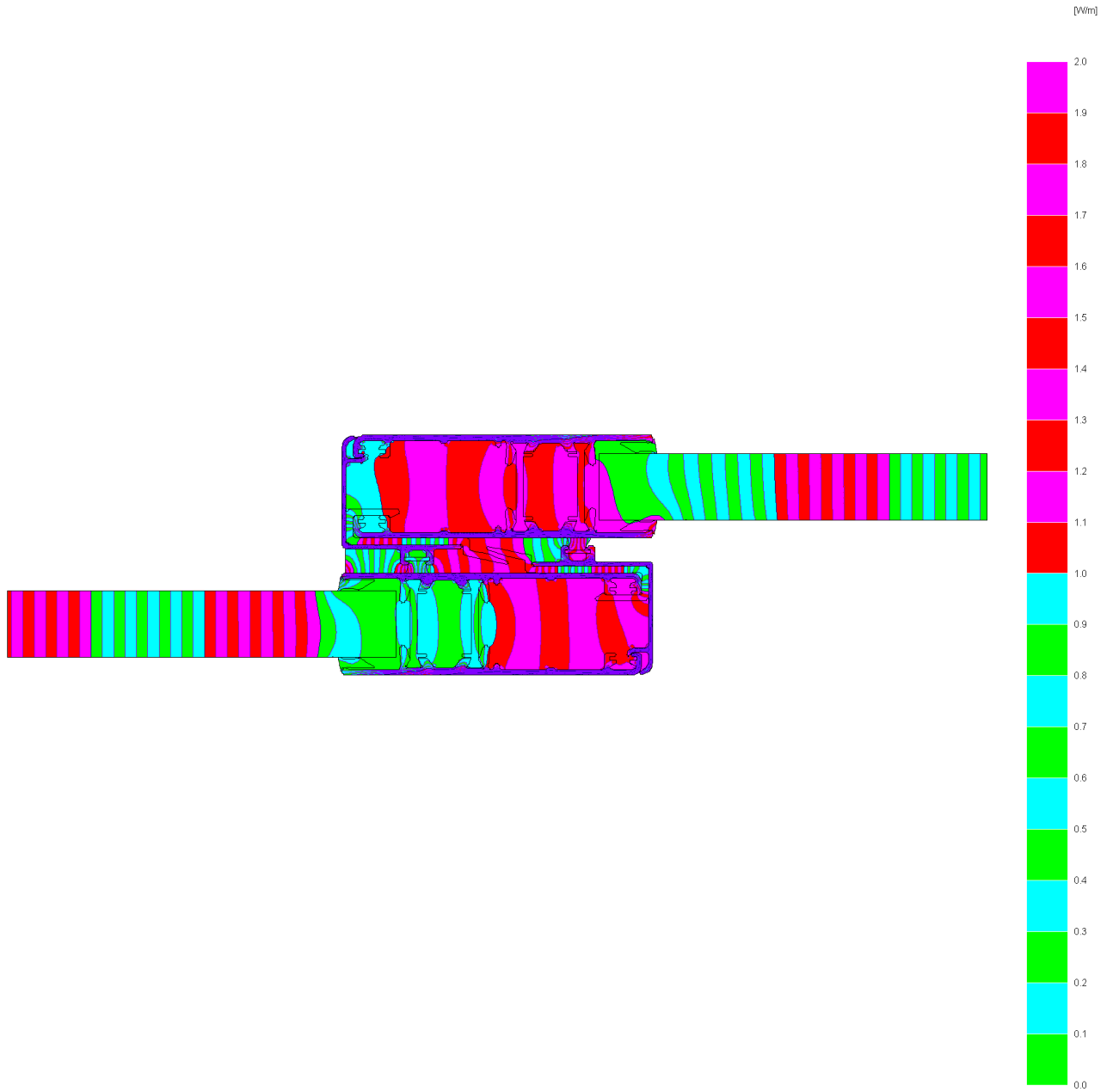



B) mediante RADCON con “Know-How” TECHNOFORM

Input – data RADCON

Col.	Name	Type	CEN-rule	Coupled	lambda [W/mK]	eps [-]	t [°C]	h [W/m²K]
8	aluminium	MATERIAL			160.000	0.90		
28	insulation	MATERIAL			0.035	0.90		
36	polyamid nylon	MATERIAL			0.250	0.90		
44	polyamid reinf.	MATERIAL			0.300	0.90		
60	EPDM	MATERIAL			0.250	0.90		
67	PVC flexible	MATERIAL			0.140	0.90		
79	mohair sweep	MATERIAL			0.140	0.90		
119	temp. sensor 1	MATERIAL			160.000	0.90		
135	temp. sensor 2	MATERIAL			160.000	0.90		
151	temp. sensor 3	MATERIAL			160.000	0.90		
156	insulation far	MATERIAL			0.035	0.90		
167	temp. sensor 4	MATERIAL			160.000	0.90		
170	exterior	BC_SKY	NIHIL					
174	interior 1	BC_SKY	NIHIL					
182	interior 2	BC_SKY	NIHIL					
190	interior 3	BC_SKY	NIHIL					
214	cavity	BC_FREE	CEN_VF_I	NO				
215	cavity	BC_FREE	CEN_VF_I	NO				
216	cavity	EQUIMAT	CEN_VF_I	NO	0.063	0.90		
217	cavity	EQUIMAT	CEN_VF_I	NO	0.063	0.90		
218	cavity	BC_FREE	CEN_VF_I	NO				
219	cavity	BC_FREE	CEN_VF_I	NO				
220	cavity	EQUIMAT	CEN_VF_I	NO	0.055	0.90		
240	cavity	EQUIMAT	CEN_VF_E	NO	0.095	0.90		
249	cavity <5x5 mm2	MATERIAL			0.040	0.90		
250	cavity <4x4 mm2	MATERIAL			0.037	0.90		
251	cavity <3x3 mm2	MATERIAL			0.034	0.90		
252	cavity <2x2 mm2	MATERIAL			0.031	0.90		
253	cavity <1x1 mm2	MATERIAL			0.028	0.90		

Col.	q [W/m²]	ta [°C]	hc [W/m²K]	qc [W/m]	tr [°C]	C1 [-]	C2 [-]	C3 [-]
8								
28								
36								
44								
60								
67								
79								
119								
135								
151								
156								
167								
170	0	0.0	12.00		0.0			
174	0	20.0	2.50		20.0			



182	0	20.0	2.88		20.0			
190	0	20.0	2.98		20.0			
214	0		2.40	0		0.0245	0.58	0.25
215	0		2.12	0		0.0245	0.58	0.25
216						0.0245	0.58	0.25
217						0.025	0.58	0.25
218	0		2.16	0		0.025	0.58	0.25
219	0		2.08	0		0.025	0.58	0.25
220						0.0247	0.58	0.25
240						0.0246	0.58	0.25
249								
250								
251								
252								
253								

Calculation parameters

Contour approximation margin (triangulation) = 0 pixels

Iteration cycles = 5

Nonlinear radiation

Recalculation of CEN values (before each iteration cycle)

Smallest accepted viewfactor = 0.001

Number of visibility rays between radiative surfaces = 100

Black radiation heat transfer coeff. (linear radiation) = 5.25 W/m²K

Maximum number of iterations (per iteration cycle) = 10000

Maximum temperature difference = 0.0001°C

Max. heat flow divergence for total object = 0.001 %

Max. heat flow divergence for any node = 1 %



Output – data RADCON

Col.	Name	Type	tmin [°C]	tmax [°C]	ta [°C]	flow in [W/m]	flow out [W/m]
8	aluminium	MATERIAL	2.63	13.08			
28	insulation	MATERIAL	1.32	16.09			
36	polyamid nylon	MATERIAL	4.19	11.56			
44	polyamid reinf.	MATERIAL	2.65	13.06			
60	EPDM	MATERIAL	2.16	13.83			
67	PVC flexible	MATERIAL	3.52	12.15			
79	mohair sweep	MATERIAL	4.21	11.55			
119	temp. sensor 1	MATERIAL	15.56	15.56			
135	temp. sensor 2	MATERIAL	13.04	13.04			
151	temp. sensor 3	MATERIAL	12.63	12.64			
156	insulation far	MATERIAL	1.48	16.31			
167	temp. sensor 4	MATERIAL	13.01	13.01			
170	exterior	BC_SKY	1.32	9.72		0.00	13.82
174	interior 1	BC_SKY	13.08	16.31		4.44	0.00
182	interior 2	BC_SKY	5.40	15.51		4.58	0.00
190	interior 3	BC_SKY	12.55	13.08		4.81	0.00
214	cavity	BC_FREE	2.65	5.22	3.92	0.68	0.61
215	cavity	BC_FREE	2.65	5.36	3.93	0.23	0.23
216	cavity	EQUIMAT	2.63	5.92			
217	cavity	EQUIMAT	9.27	13.09			
218	cavity	BC_FREE	9.85	13.05	11.48	0.27	0.27
219	cavity	BC_FREE	10.00	13.00	11.71	0.71	0.71
220	cavity	EQUIMAT	4.24	11.49			
240	cavity	EQUIMAT	3.61	9.81			
249	cavity <5x5 mm2	MATERIAL	4.61	10.58			
250	cavity <4x4 mm2	MATERIAL	4.19	11.55			
251	cavity <3x3 mm2	MATERIAL	3.08	12.59			
252	cavity <2x2 mm2	MATERIAL	2.33	13.59			
253	cavity <1x1 mm2	MATERIAL	2.53	13.26			



Cálculo del coeficiente de transmisión térmica (Uf)

THERMAL TRANSMITTANCE ACCORDING TO prEN 10077-2

Theory

The thermal transmittance of a frame according to PrEN 10077-2:

$$U_f = \frac{L_{2D} - U_p * l_p}{l_f} \quad \text{and} \quad L_{2D} = \frac{q_{l,tot}}{\Delta \theta}$$

- with:
- U_f : thermal transmittance of the window frame [W/m²K]
 - U_p : thermal transmittance of the flanking panel [W/m²K]
 - l_p : projected width of the flanking panel [m]
 - l_f : projected width of the window frame [m]
 - L_{2D} : two-dimensional coupling coefficient [W/mK]
 - $q_{l,tot}$: total heat flow through the window frame and the flanking panel [W/m]
 - $\Delta \theta$: temperature difference between inside (θ_i) and outside (θ_e) [K]

Calculation	Item:		
input data:	$q_{l,tot} =$	13,82 W/m	$R_{se} =$ 0,06 m ² K/W
	$\theta_e =$	0,0 °C	$R_{si} =$ 0,13 m ² K/W
	$\theta_i =$	20,0 °C	
	$d_i =$	0,019 m	
	$\lambda_i =$	0,035 W/m*K	
	$U_p =$	1,367 W/m ² K	
	$l_p =$	0,190 m	
	calculation results:		$L_{2D} =$ 0,69 W/mK
	$l_f =$	0,0880 m	$U_f =$ 4,90 W/m ² K

input data using the Physibel Software BISCO

- $q_{l,tot}$: alphanumeric output BISCO
heat losses per boundary condition
- $\Delta \theta$: input data, surface boundary conditions:
inside temperature minus outside temperature
- U_p : calculation, using the following formula:

$$U_p = \left[\frac{1}{h_e} + \sum \frac{d_i}{\lambda_i} + \frac{1}{h_i} \right]^{-1}$$

- with: h_e / h_i ext./int. surface heat transfer coeff. [W/m²K]
- d_i thickness of layer i [m]
- λ_i thermal conductivity of layer i [W/mK]

- l_p / l_f : input data: dimensions of the item

PHYSIBEL Heirweg 21 B-9990 Maldegem Belgium tel +32 50 711432 fax +32 50 717842